

# BACK PRESSURE RELIEF VALVES

## 3040 Series Relief and Back Pressure

Watson McDaniel reserves the right to change the designs and/or materials of its products without notice.  
©2004 Watson McDaniel Company

Revised 9/2004

|                     |   |
|---------------------|---|
| Model               | 3040 Series   |
| Service             | Water, Oil, other Liquids   |
| Sizes               | 1/2", 3/4", 1", 1 1/4", 1 1/2", 2"  |
| Connections         | NPT, 125# & 250# Flanged  |
| Body Material       | 1/2"– 1 1/2" Bronze Threaded<br>2" Cast Iron Threaded<br>2" Cast Iron Flanged |
| Disc Material       | Buna-N/Teflon – 200°F maximum<br>Viton up to 300°F (optional)                 |
| Diaphragm           | Neoprene/Nylon–200°F maximum<br>Viton up to 300°F (optional)                  |
| Max. Inlet Pressure | 250 PSIG  |



### DESIGN PRESSURE/TEMPERATURE RATING – PMA/TMA

|          |                   |
|----------|-------------------|
| NPT      | 300 PSIG @ 200° F |
| 125# FLG | 125 PSIG @ 200° F |
| 250# FLG | 250 PSIG @ 200° F |

### TYPICAL APPLICATIONS

The **3040 Series** Back Pressure Valves relieve upstream pressure in a variety of processes. Automatically maintains desired maximum pressure in a vessel or system by relieving excess pressure into lower pressure return line or to atmosphere. Ideally suited for use as pump bypass control valve by maintaining constant pump discharge pressures. Used as a continuously operating valve for protection against overpressure conditions.

**Caution:** Not to be used as an emergency or safety relief valve.

### FEATURES & OPTIONS

- Soft Seat for tight shut-off
- Easy maintenance
- Self-contained
- Fast response
- Accurate control
- Optional Viton trim for 300° F service

### PRESSURE ADJUSTMENT

Rotating the adjustment screw clockwise increases the compression on the spring thereby increasing the set pressure. Rotating the adjustment screw counter-clockwise, lowers the set pressure. Tighten lock nut after adjustment.

### HOW TO ORDER

Specify: • Regulator **3040 Series**  
• Size based on capacity chart  
• Spring range or relief pressure

Example: **2" 3040 Series – 5-35 lbs. Spring Range**

### PRESSURE-ADJUSTING SPRING RANGES

| Relief Pressure (PSIG) | Spring No.         |
|------------------------|--------------------|
| 1-12                   | 4 (1/2" – 1" only) |
| 5-35                   | 3                  |
| 20-70                  | 2                  |
| 40-125                 | 1                  |

### DIMENSIONS & WEIGHTS – inches/pounds

| Size   | Face-to-Face<br>A               |                                |                                | B                              | C                              | Weight<br>(lbs) |
|--------|---------------------------------|--------------------------------|--------------------------------|--------------------------------|--------------------------------|-----------------|
|        | Screwed                         | 125#<br>Flanged                | 250#<br>Flanged                |                                |                                |                 |
| 1/2"   | 4 <sup>1</sup> / <sub>8</sub>   |                                |                                | 2 <sup>5</sup> / <sub>16</sub> | 9                              | 10              |
| 3/4"   | 4 <sup>1</sup> / <sub>8</sub>   |                                |                                | 2 <sup>5</sup> / <sub>16</sub> | 9                              | 10              |
| 1"     | 4 <sup>1</sup> / <sub>8</sub>   |                                |                                | 2 <sup>5</sup> / <sub>16</sub> | 9                              | 10              |
| 1 1/4" | 4 <sup>13</sup> / <sub>16</sub> |                                |                                | 3 <sup>1</sup> / <sub>4</sub>  | 12 <sup>3</sup> / <sub>4</sub> | 15              |
| 1 1/2" | 5 <sup>3</sup> / <sub>16</sub>  |                                |                                | 3 <sup>1</sup> / <sub>2</sub>  | 13 <sup>1</sup> / <sub>4</sub> | 17              |
| 2"     | 9 <sup>1</sup> / <sub>2</sub>   | 10 <sup>3</sup> / <sub>8</sub> | 10 <sup>7</sup> / <sub>8</sub> | 5 <sup>1</sup> / <sub>2</sub>  | 16 <sup>3</sup> / <sub>4</sub> | 45              |

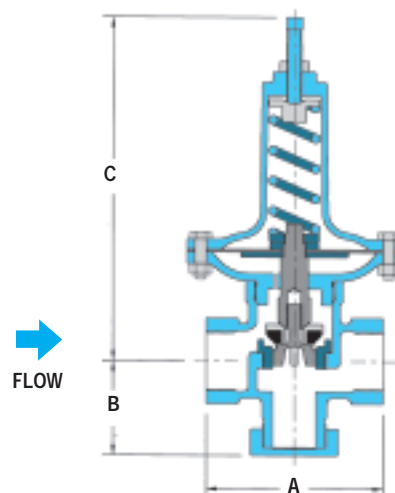

# BACK PRESSURE RELIEF VALVES

## 3040 Series

### Relief and Back Pressure

Revised 9/2004

#### CAPACITIES – Water (gpm)

|              |                     | At 10% Over Set Pressure |      |      |        |        |     |
|--------------|---------------------|--------------------------|------|------|--------|--------|-----|
| Spring Range | Set Pressure (PSIG) | 1/2"                     | 3/4" | 1"   | 1 1/4" | 1 1/2" | 2"  |
| 1-12         | 5                   | 4.0                      | 8.0  | 10.0 |        |        |     |
| 5-35         | 10                  | 5.7                      | 11.4 | 14.3 | 29     | 43     | 71  |
| 5-35         | 20                  | 8.1                      | 16.2 | 20.3 | 41     | 61     | 101 |
| 20-70        | 50                  | 12.7                     | 25.4 | 31.8 | 64     | 95     | 159 |
| 20-70        | 75                  | 15.6                     | 31.2 | 39.0 | 78     | 117    | 195 |
| 40-125       | 100                 | 18.0                     | 36.0 | 45.0 | 90     | 135    | 225 |
| 40-125       | 125                 | 20                       | 40   | 50   | 100    | 150    | 250 |

|              |                     | At 20% Over Set Pressure |      |      |        |        |     |
|--------------|---------------------|--------------------------|------|------|--------|--------|-----|
| Spring Range | Set Pressure (PSIG) | 1/2"                     | 3/4" | 1"   | 1 1/4" | 1 1/2" | 2"  |
| 1-12         | 5                   | 4.4                      | 8.8  | 11.2 |        |        |     |
| 5-35         | 10                  | 6.3                      | 12.5 | 16.0 | 32     | 47     | 79  |
| 5-35         | 20                  | 8.9                      | 17.8 | 22.7 | 45     | 67     | 113 |
| 20-70        | 50                  | 14.0                     | 27.  | 35.6 | 71     | 105    | 177 |
| 20-70        | 75                  | 17.2                     | 34.3 | 43.7 | 87     | 129    | 217 |
| 40-125       | 100                 | 19.8                     | 39.6 | 50.4 | 101    | 149    | 250 |
| 40-125       | 125                 | 22                       | 44   | 56   | 112    | 166    | 278 |

The 3040 Series Relief Valve water capacities at both 10% and 20% over "Set Pressure" are tabulated in the above table. Enter the chart at the desired "Set Pressure" in the left-hand column and read the capacity in GPM to determine proper Valve Size. Select a spring with a relief range that includes the "Set Pressure" required. **Example: A 1" valve set at 50 psig will pass 35.6 GPM if the system pressure exceeds the set point by 20%.**

#### HOW IT WORKS

The 3040 Series Back Pressure Valve senses upstream pressure acting on the underside of the diaphragm through a port in the bottom diaphragm case. An increase in the upstream pressure above the set point will compress the spring and allow the valve to open. The spring will close the valve as the upstream pressure decreases to the set point.

The higher the system pressurizes above the relief set point pressure, the more flow the valve will pass. It is therefore typical to specify the maximum capacity of a back pressure relief valve at 10% & 20% over set pressure.

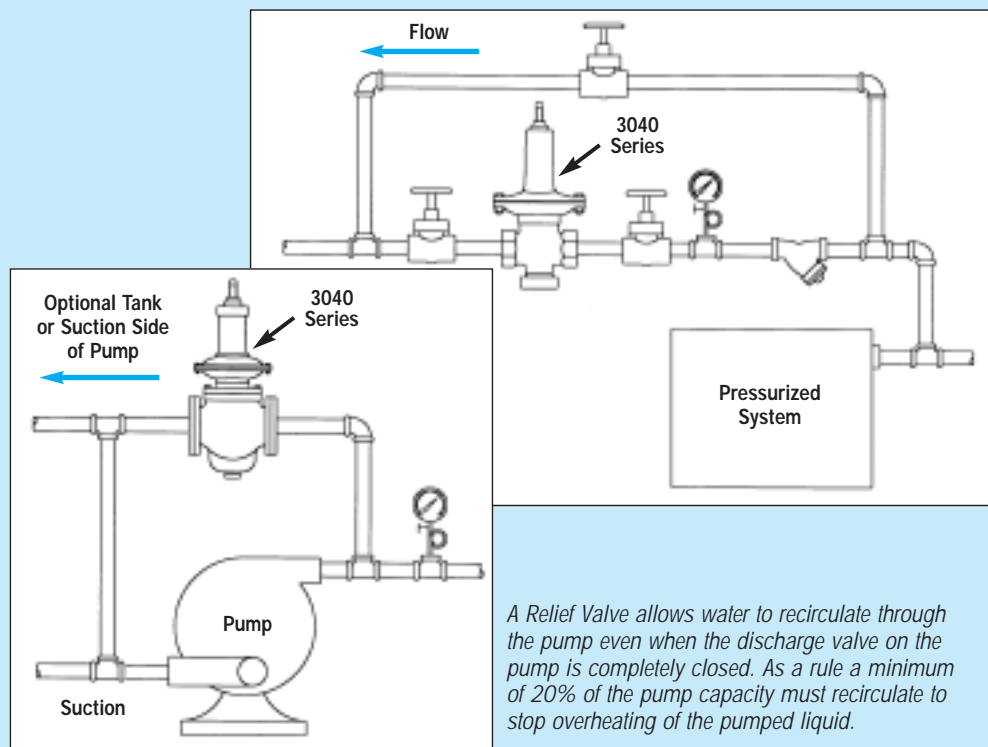

A Relief Valve allows water to recirculate through the pump even when the discharge valve on the pump is completely closed. As a rule a minimum of 20% of the pump capacity must recirculate to stop overheating of the pumped liquid.

REGULATORS