

NON-ELECTRIC CONDENSATE PUMPS

PMP Series

Pressure Motive Pumps

Watson McDaniel reserves the right to change the designs and/or materials of its products without notice.
©2004 Watson McDaniel Company

Revised 9/2004

TYPICAL APPLICATION

The Watson McDaniel **PMP Series of Pressure Motive Pumps** are designed to transfer liquids, normally condensate, without the use of electrical energy. The primary application for the PMP is pumping condensate from a process application or condensate collection area back to the return system.

Hot Condensate The mechanical seals in standard electric condensate return pumps begin to have difficulty when handling condensate in excess of 195° F. Seal failure is virtually guaranteed when condensate temperatures reach 203° F due to flashing of the condensate across the seal face. It is therefore required to cool condensate in order to prevent seal failure prior to pumping using electric pumps. PMPs do not have seals and therefore will handle condensate well in excess of these temperatures.

Several choices of pump body materials, types and configurations are available to meet specific customer applications:

Ductile Iron Tanks Ductile Iron is far superior to cast iron in handling higher pressures and temperatures. Ductile iron is also extremely corrosive resistant to condensate and water and can last in excess of 50 years before tank replacement is required. Our ductile iron tanks can be ASME coded on request.

Fabricated Carbon Steel Carbon steel has a higher pressure and temperature rating than ductile iron. Certain industrial facilities such as chemical and petrochemical refineries request carbon steel only. Our carbon steel tanks come standard ASME coded.

Fabricated Stainless Steel Stainless steel (304L) tanks are the most corrosive resistant and can be used in extremely harsh environments.

Low Profile Low profile tanks are often required when draining condensate from process equipment when positioned close to the ground which limits filling head. Low profile units are available in both fabricated steel and cast iron.

Sump Drainers Sump drainers are similar to the standard PMP models except that they discharge the condensate vertically upwards. This piping configuration allows them to be easily fit into below ground sump pits with limited space.

High Pressure Standard units have a maximum discharge pressure of 150 PSIG. High pressure (PMPHP) units can discharge condensate up to 200 PSIG and are used for returning condensate against systems with high back pressure.

TYPICAL CONFIGURATIONS

Stand-Alone: PMP pump unit with inlet and outlet check valves.

Simplex: One Pumping unit with check valves and receiver tank, mounted on frame and skid base.

Duplex: Two Pumping units with check valves and receiver tank, mounted on frame and skid base..

Triplex: Three Pumping units with check valves and receiver tank, mounted on frame and skid base.

Quadraplex: Four Pumping units with check valves and receiver tank, mounted on frame and skid base.

CUSTOM CONFIGURATIONS

Watson McDaniel's fully-qualified fabrication facility is ASME code certified. Our engineers can design and build complete custom systems to meet all your requirements.

FEATURES

- **Seal-less** – The PMP contains no seals. The weak point in conventional electric pumps is seal failure due to flashing hot condensate across the seal face.
- **Non-Electric** – Since no electricity is required they can be used in remote locations or NEMA 4,7 & 9 hazardous areas. Can operate using steam, air, nitrogen or other pressurized gases as the motive force.
- **Ductile-Iron** – Pump tanks are standard in Ductile-Iron which is far superior to Cast-Iron for pressure and temperature rating and safety. Can be ASME coded and can last in excess of fifty years prior to replacement.
- **Carbon Steel** – Pump tanks available in ASME coded carbon steel.
- **Stainless Steel** – Pump tank options include 304L for applications in harsh environments.

OPTIONS

- Cycle counter for measuring the amount of condensate flow through the pump.
- Insulation jackets are available to stop radiation losses through the pump body and provide personal protection.
- Sight glass for monitoring liquid level inside pump body.
- ASME code-certified fabrication facility for the design and manufacture of customized systems.

NON-ELECTRIC CONDENSATE PUMPS

PMP Series

Pressure Motive Pumps

Revised 9/2004

Function of PMP Pressure Motive Pump

PUMPS

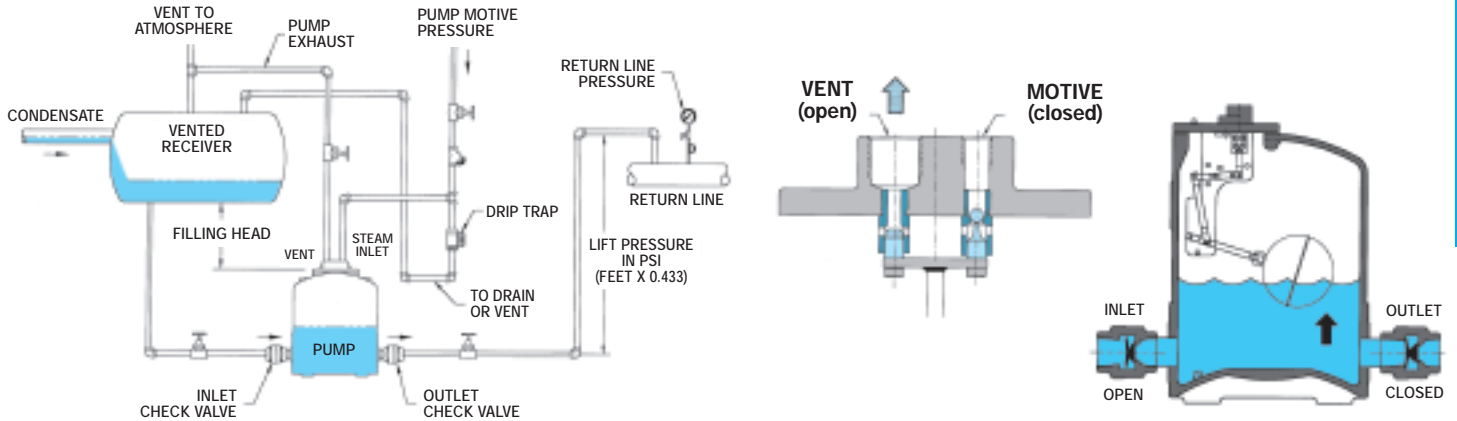

1 Condensate flows from the receiver tank thru the inlet check valve and fills the pump tank. During the filling cycle the float inside the tank rises.

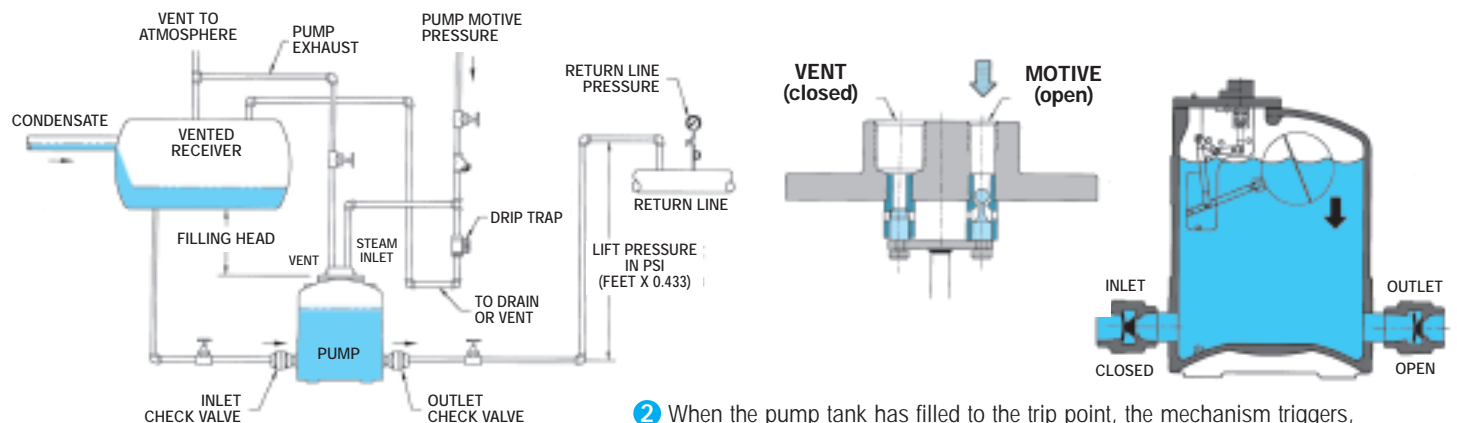

2 When the pump tank has filled to the trip point, the mechanism triggers, opening the steam inlet valve and simultaneously closing the vent valve. This allows motive pressure to enter the pump body.

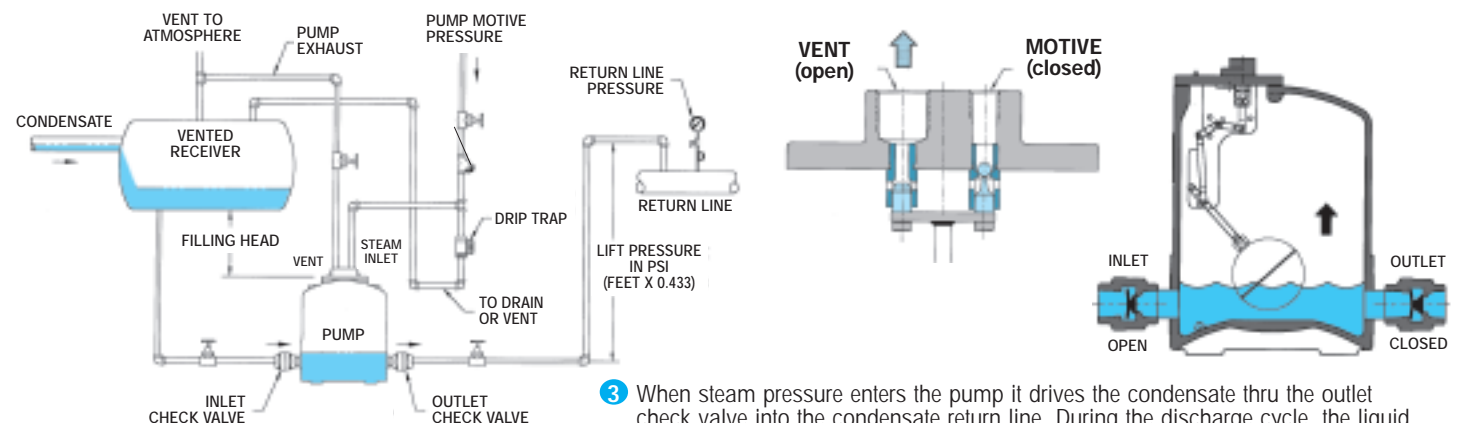

3 When steam pressure enters the pump it drives the condensate thru the outlet check valve into the condensate return line. During the discharge cycle, the liquid and the float inside the pump tank drops. At the lower trip point, the mechanism triggers and the steam inlet valve to the pump tank closes and simultaneously the vent valve opens. The fill and discharge cycle then repeats itself.

NON-ELECTRIC CONDENSATE PUMPS

PMP Series

Pressure Motive Pumps

Watson McDaniel reserves the right to change the designs and/or materials of its products without notice.
©2004 Watson McDaniel Company

Revised 9/2004

Open Loop System (Vented Receiver)

TYPICAL INSTALLATIONS

When utilizing a PMP Series Pump in an "open-loop" system a receiver tank that is vented to atmosphere must be installed above the pump to provide enough hydraulic head to move the condensate into the pump since it has lost all its pressure to atmosphere along with the flash steam. This is particularly necessary when there are multiple condensate sources at very different pressures dumping into a common receiver. The receiver vented to atmosphere equalizes the discharge pressure of all the steam traps thus preventing a trap operating at higher pressure from stalling a trap operating at a lower pressure.

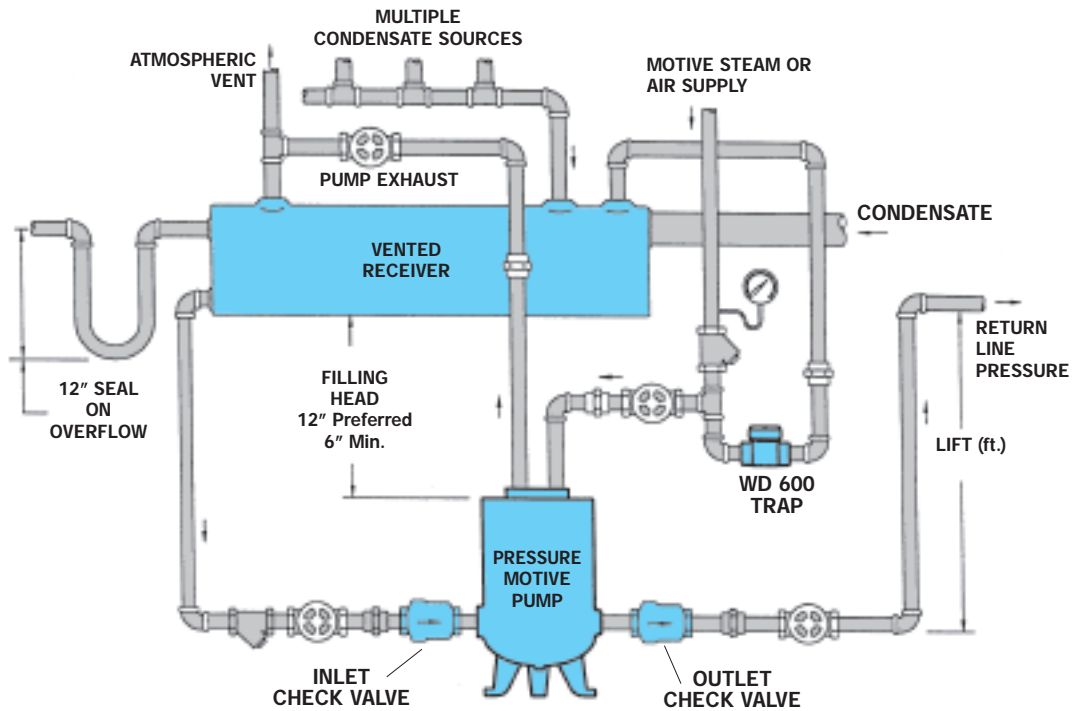

Closed Loop System (Pressurized Reservoir)

TYPICAL INSTALLATIONS

When utilizing a PMP Series Pump in a "closed-loop" system a reservoir tank that is not vented to atmosphere must be installed above the pump to provide a hydraulic head and a holding area for the condensate when the pump is in its discharge cycle. The "closed-loop" system is used to drain a single piece of heat-transfer equipment where the venting of flash steam is not desired or when the condensate return pressure exceeds the steam pressure inside the equipment. This causes the common steam trap system to stall and back condensate up into the equipment.

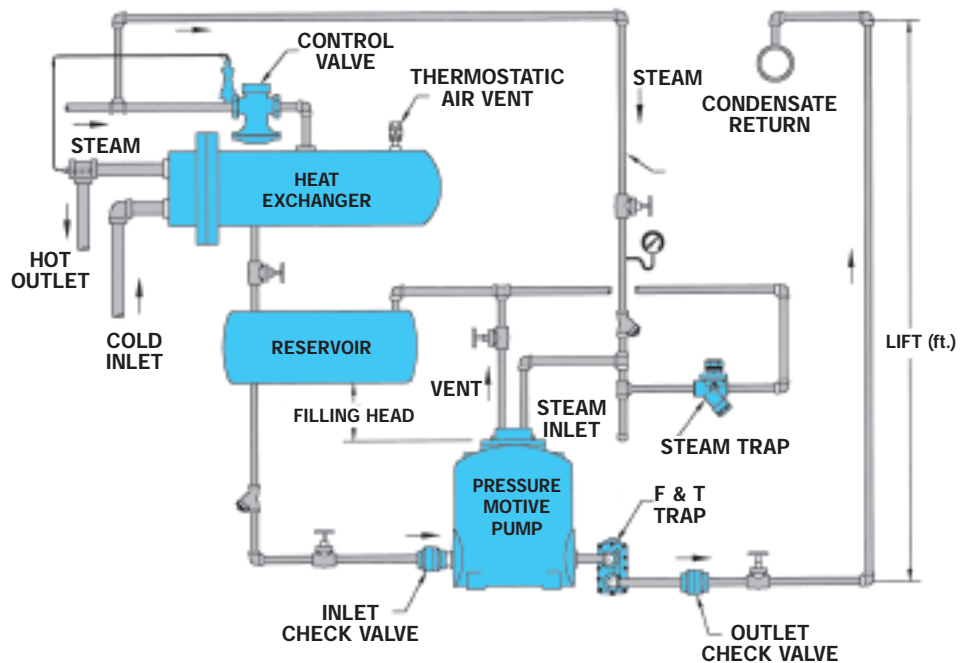

NON-ELECTRIC CONDENSATE PUMPS

PMP Series

Pressure Motive Pumps

Revised 9/2004

Problem: Stalled Heat Exchanger

DESCRIPTION

STALL CONDITION WITH MODULATED STEAM FLOW.

Steam flowing into the heat exchanger is controlled by the temperature regulating valve. When the temperature regulating valve is fully open, any condensate forming inside the heat exchangers will be pushed through the steam trap into the condensate return line. When the temperature regulating valve partially or fully closes the steam pressure inside the heat exchangers can no longer overcome the back pressures and the condensate will build up in the heat exchanger. This condition is called system stall and results in water hammer and poor heat transfer due to the condensate build-up in the heat exchanger.

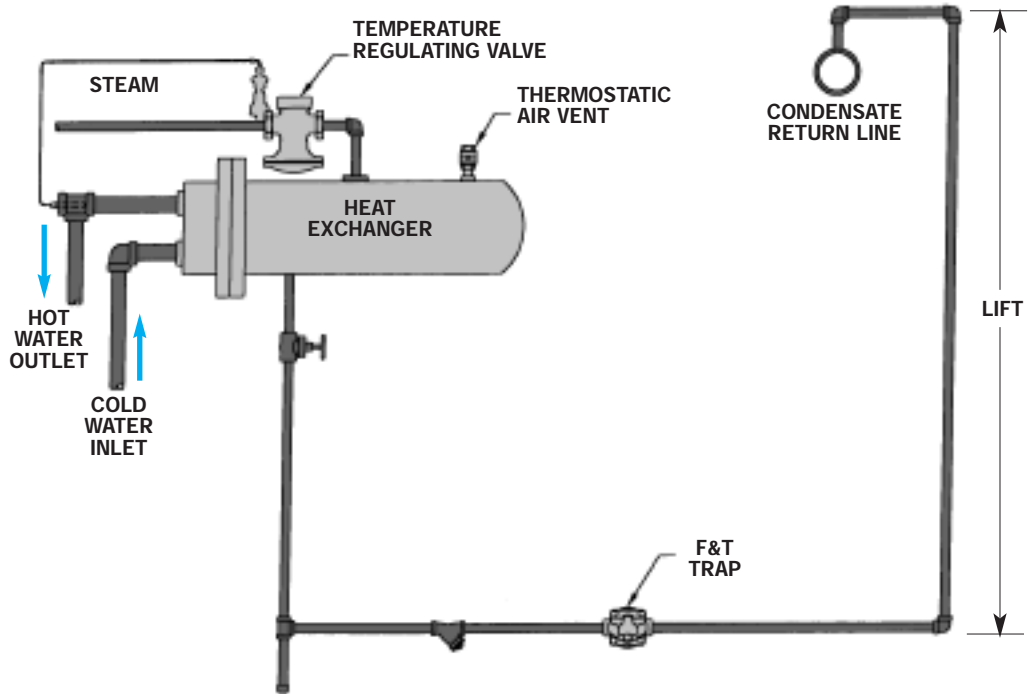

Solution:

DESCRIPTION:

USE A PRESSURE MOTIVE PUMP AS SHOWN

When the temperature regulating valve is fully open, any condensate forming inside the heat exchangers will be pushed through the pump and steam trap into condensate return line. When the temperature regulating valve closes, any condensate forming inside the heat exchanger will drain by gravity into the pump tank. When the level inside the pump tank reaches the trip point, high pressure steam will drive the condensate from the tank into the condensate return line.

Note: A larger steam trap than normally required to drain the heat exchanger must be used to handle the high instantaneous discharge rate of the pump.

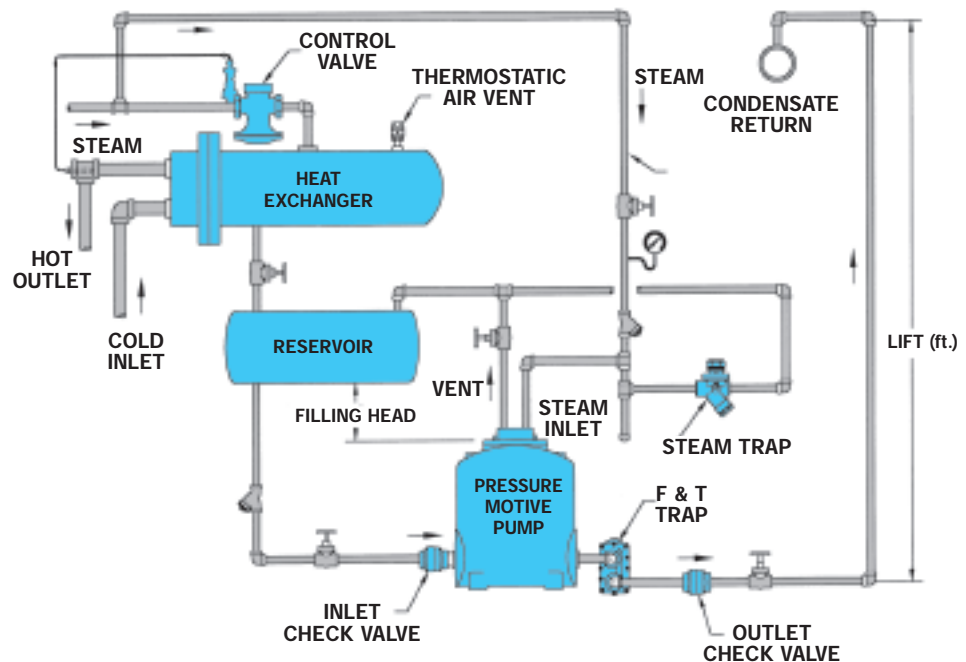

NON-ELECTRIC CONDENSATE PUMPS

PMP Series

Pressure Motive Pumps

Watson McDaniel reserves the right to change the designs and/or materials of its products without notice.
©2004 Watson McDaniel Company

Revised 9/2004

The following models of the PMP Series all have identical internal mechanisms. The only difference between each model is the body and cover material.

PMPC



DUCTILE IRON

PMPF



CARBON STEEL

PMPSS



STAINLESS STEEL

PMPLS



LOW PROFILE

PMPSP



CARBON STEEL
SUMP DRAINER

TYPICAL APPLICATIONS

The Watson McDaniel **PMP Series** Pressure Motive Pumps are designed to transfer liquids (usually hot condensate) without the use of electrical energy. The primary application for the PMP is pumping condensate from a process application or condensate collection area back to the return system.

PUMP FEATURES

- **Seal-less** – The PMP contains no seals. The weak point in conventional electric pumps is seal failure due to flashing hot condensate across the seal face.
- **Non-Electric** – Since no electricity is required they can be used in remote locations or NEMA 4, 7 & 9 hazardous areas. Can operate using steam, air, nitrogen or other pressurized gases as the motive force.
- **Ductile-Iron** – Pump tanks are standard in Ductile-Iron which is far superior to Cast-Iron for pressure and temperature rating and safety. Can be ASME coded and can last in excess of fifty years prior to replacement.
- **Carbon Steel** – Pumps tanks available in ASME coded carbon steel.
- **Stainless Steel** – Pumps tank options include 304L for applications in harsh environments.

PMPC

The Model **PMPC** pressure motive pump body & cover are manufactured from ductile iron. **ASME “UM” code stamp available.**

PMPF

The Model **PMPF** pressure motive pump is designed for high pressure applications. Pump body & cover are manufactured from carbon steel and receive the **ASME “UM” code stamp**.

PMPSS

The Model **PMPSS** pressure motive pump body & cover are manufactured from 304L stainless steel. These tanks are designed to be used in harsh corrosive environments and receive the **ASME “UM” code stamp**.

PMPLS

The Model **PMPLS** pressure motive pumps are low profile. These tanks are often required when draining condensate from process equipment positioned close to the ground which limits the filling head of the pump. Pump body & cover are manufactured from carbon steel and receive the **ASME “UM” code stamp**.

PMPSP

The Model **PMPSP** sump drainer body & cover are manufactured from carbon steel. These tanks are fabricated with 1/8" corrosion allowance and receive the **ASME “UM” code stamp**. The Model PMPSP Sump Drainer is designed for pumping out and draining pits.

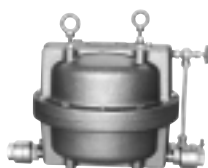

LOW PROFILE

PMPM

The Model **PMPM** pressure motive pump has an extremely low-profile. These low-profile tanks are required when draining condensate from process equipment positioned close to the ground which limits the filling head of the pump.

NON-ELECTRIC CONDENSATE PUMPS

PMP Series

Pressure Motive Pump Internal Mechanism

Revised 9/2004

PUMPS

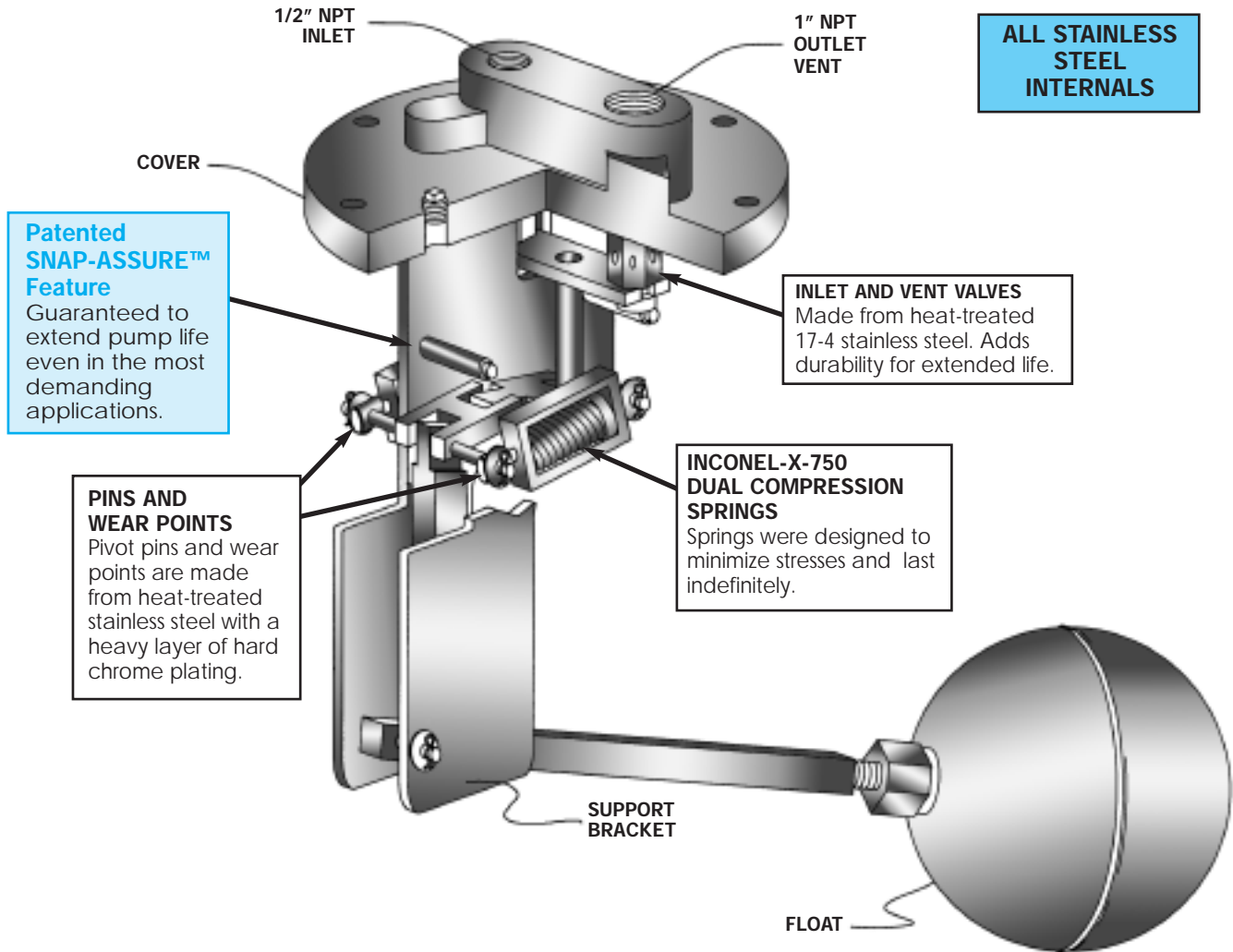

ALL STAINLESS STEEL INTERNALS

Patented SNAP-ASSURE™ Feature
Guaranteed to extend pump life even in the most demanding applications.

INLET AND VENT VALVES
Made from heat-treated 17-4 stainless steel. Adds durability for extended life.

PINS AND WEAR POINTS
Pivot pins and wear points are made from heat-treated stainless steel with a heavy layer of hard chrome plating.

INCONEL-X-750 DUAL COMPRESSION SPRINGS
Springs were designed to minimize stresses and last indefinitely.

INTERNAL MECHANISM FEATURES

- Equipped with our Patented “Snap-Assure” feature, found only on Watson McDaniel’s mechanisms. “Snap-Assure” extends the useful life of the pump by assuring the internal toggle action to trigger (snap) at every cycle.
- All Stainless Steel components eliminate corrosion and rusting
- Hard chrome-plated pivot pins and wear points substantially reduce the rate of wear on critical components
- 17-4 heat-treated stainless steel inlet and vent valve. Hardened seats have proven themselves to last years longer in service.
- Dual compression springs made from Inconel-X-750 minimize stress and corrosion and are made to last indefinitely
- Precision manufactured mechanisms never require field adjustments
- Watson McDaniel “Snap-Assure” mechanisms can be purchased separately and will fit other manufacturer’s pump tanks

INTERNAL MECHANISM MATERIALS

Cover	Material for cover same as tank material
Cover Gasket	Garlock / Grafoil
Cover Bolts	Grade B5
Inlet Valve	Hardened Stainless Steel, Rc 40
Vent Valve	Hardened Stainless Steel, Rc 40
Mechanism Yoke	304 Stainless Steel
Ball Float	Stainless Steel
Springs	Inconel-X-750
Other Internal Parts	Stainless Steel

Snap-Assure Patent No. 6572340

NON-ELECTRIC CONDENSATE PUMPS

PMP Series

Pressure Motive Pumps

Watson McDaniel reserves the right to change the designs and/or materials of its products without notice.
©2004 Watson McDaniel Company

Revised 9/2004

PUMPS

PMPC



Model	PMPC
Body	Ductile Iron
Cover	Ductile Iron
Check Valves	Stainless Steel
PMO Max. Operating Pressure	200 PSIG
TMO Max. Operating Temperature	388°F
PMA Max. Allowable Pressure	200 PSIG @ 650°F

DESCRIPTION

The Model **PMPC** pressure motive pump body & cover is manufactured from ductile iron. **ASME "UM" code stamp available.**

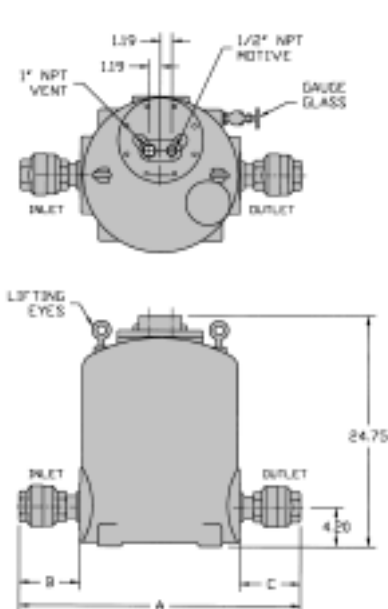

PMPF



Model	PMPF
Body	Carbon Steel
Cover	Carbon Steel
Check Valves	Stainless Steel
PMO Max. Operating Pressure	200 PSIG
TMO Max. Operating Temperature	388°F
PMA Max. Allowable Pressure	250 PSIG @ 650°F

DESCRIPTION

The Model **PMPF** pressure motive pump is designed for high pressure applications. Pump body & cover are manufactured from carbon steel and receive the **ASME "UM" code stamp**.

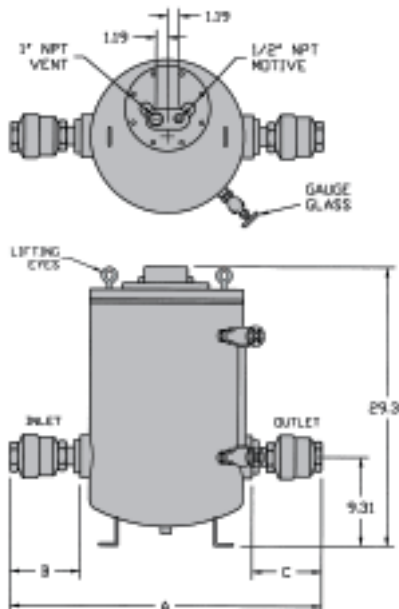

PMPSS



Model	PMPSS
Body	304L SS
Cover	304L SS
Check Valves	Stainless Steel
PMO Max. Operating Pressure	150 PSIG
TMO Max. Operating Temperature	366°F
PMA Max. Allowable Pressure	150 PSIG @ 650°F

DESCRIPTION

The Model **PMPSS** pressure motive pump body & cover is manufactured from 304L stainless steel. These tanks are designed to be used in harsh corrosive environments and receive the **ASME "UM" code stamp**.

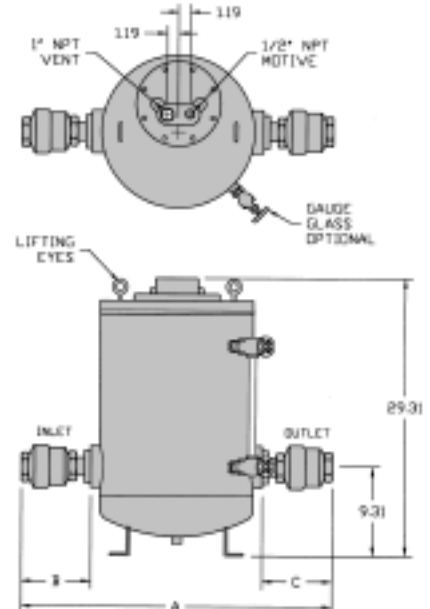

NON-ELECTRIC CONDENSATE PUMPS

PMP Series

Pressure Motive Pumps

Revised 9/2004

PMPLS



Model	PMPLS
Body	Carbon Steel
Cover	Carbon Steel
Check Valves	Stainless Steel
PMO Max. Operating Pressure	150 PSIG
TMO Max. Operating Temperature	366°F
PMA Max. Allowable Pressure	150 PSIG @ 650°F

Note: Optional 200 PSIG PMA/PMO. Consult Factory.

DESCRIPTION

The Model **PMPLS** pressure motive pumps are low profile. These tanks are often required when draining condensate from process equipment that is positioned close to the ground which limits the filling head of the pump. Pump body & cover are manufactured from carbon steel and are ASME "UM" code stamped.

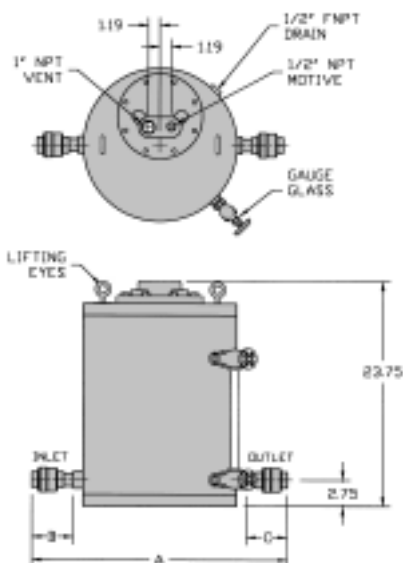

PMPSP SUMP DRAINER



Model	PMPSP
Body	Carbon Steel
Cover	Carbon Steel
Check Valves	Stainless Steel
PMO Max. Operating Pressure	150 PSIG
TMO Max. Operating Temperature	366°F
PMA Max. Allowable Pressure	150 PSIG @ 650°F

DESCRIPTION

The Model **PMPSP** sump drainer is designed for pumping out & draining pits. Pump body & cover are manufactured from carbon steel and are ASME "UM" code stamped.

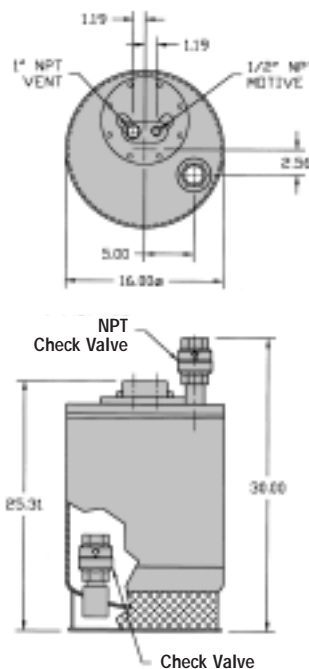

DIMENSIONS — inches / pounds

Size Inlet x Outlet	A	B	C	Weight (lbs)
PMPC				
1" x 1"	29 1/2	6	6	360
1 1/2" x 1"	30 3/4	7 1/2	6	365
2" x 1"	31	8	6	370
2" x 1 1/2"	32 1/2	8	7 1/2	380
2" x 2"	32 3/4	8	8	385
3" x 2"	35 1/4	9 1/4	8	390
PMPE				
1" x 1"	30 1/2	6	6	215
1 1/2" x 1"	31 3/4	7 1/2	6	220
2" x 1"	32	8	6	225
2" x 1 1/2"	33 1/2	8	7 1/2	330
2" x 2"	33 3/4	8	8	335
3" x 2"	35 1/4	9 1/4	8	340
PMPS				
1" x 1"	30 1/2	6	6	215
1 1/2" x 1"	31 3/4	7 1/2	6	220
2" x 1"	32	8	6	225
2" x 1 1/2"	33 1/2	8	7 1/2	230
2" x 2"	33 3/4	8	8	235
3" x 2"	35 1/4	9 1/4	8	340
PMPLS				
1" x 1"	29 1/2	5 5/8	5 5/8	200
1 1/2" x 1"	30 3/4	7	5 5/8	205
1 1/2" x 1 1/2"	32 1/8	7	7	210

PUMPS