

NON-ELECTRIC CONDENSATE PUMPS

PMPM

Pressure Motive Pump

Watson McDaniel reserves the right to change the designs and/or materials of its products without notice.
©2004 Watson McDaniel Company

Revised 9/2004

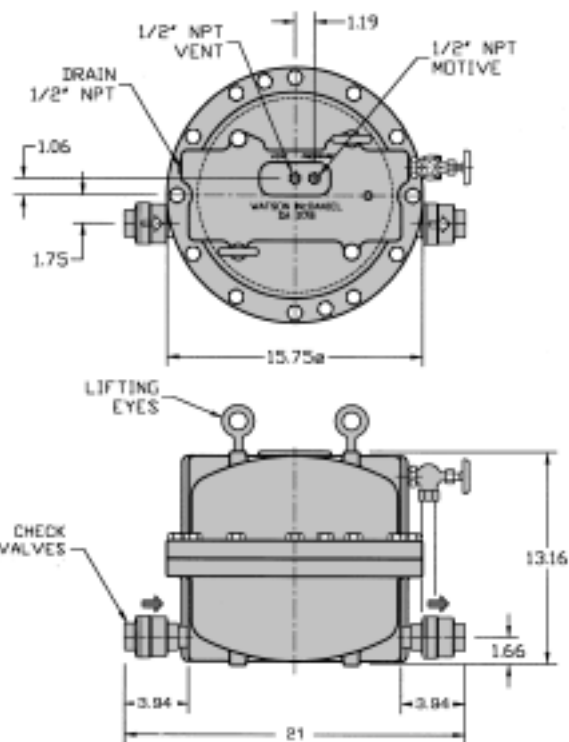
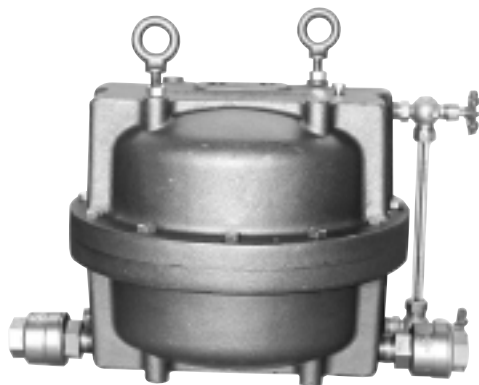

Model	PMPM
Body	Cast Iron
Cover	Cast Iron
Sizes	1", 1-1/4"
Check Valves	Stainless Steel
PMO Max. Operating Pressure	150 PSIG
TMO Max. Operating Temperature	366°F
PMA Max. Allowable Pressure	150 PSIG @ 450°F

TYPICAL APPLICATIONS

The Model PMPM pressure motive pump has an **extremely low-profile**. These low-profile tanks are required when draining condensate from process equipment positioned close to the ground which limits the filling head of the pump.

FEATURES

- Mechanism incorporates **heat-treated stainless steel wear items** for extended service life
- All stainless steel internals for ultimate corrosion resistance
- Dual springs made from Inconel-X-750 for high-temperature corrosive service
- Operates using steam, air, nitrogen or other pressurized gases as the motive force
- Low-profile design
- **Non-Electric** – can be used in remote locations or NEMA 4, 7, 9 & hazardous areas

MATERIALS

Body & Cover	Cast Iron
Cover Gasket	Garlock
Cover Bolts	Steel
Inlet Valve	Hardened Stainless Steel 40 Rc
Vent Valve	Hardened Stainless Steel 40 Rc
Mechanism Yoke	304 Stainless Steel
Ball Float	304 Stainless Steel
Check Valves	Stainless Steel
Springs	Inconel-X-750
Other Internal Comp	Stainless Steel

NON-ELECTRIC CONDENSATE PUMPS

PMPM

Pressure Motive Pump

Revised 9/2004

Problem

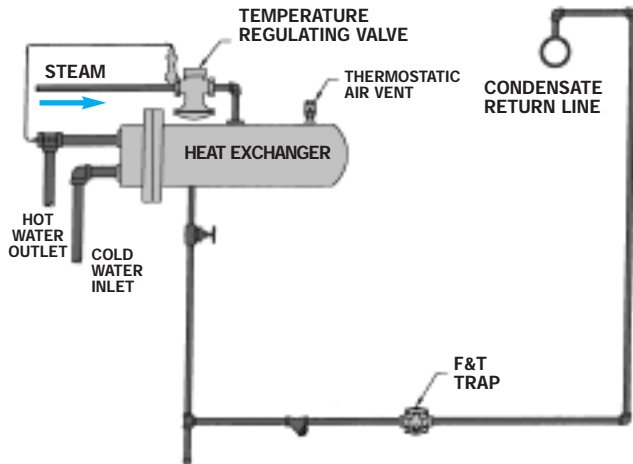

PROBLEM

STALL CONDITION WITH MODULATED STEAM FLOW.

Steam flowing into the heat exchanger is controlled by the temperature regulating valve. When the temperature regulating valve is fully open, any condensate forming inside the heat exchangers will be pushed through the steam trap into the condensate return line. When the temperature regulating valve partially or fully closes the steam pressure inside the heat exchanger can no longer overcome the back pressure against the outlet of the trap and the condensate will build up in the heat exchanger. This condition is called system stall and results in water hammer and poor heat transfer due to the condensate build-up in the heat exchanger.

Solution

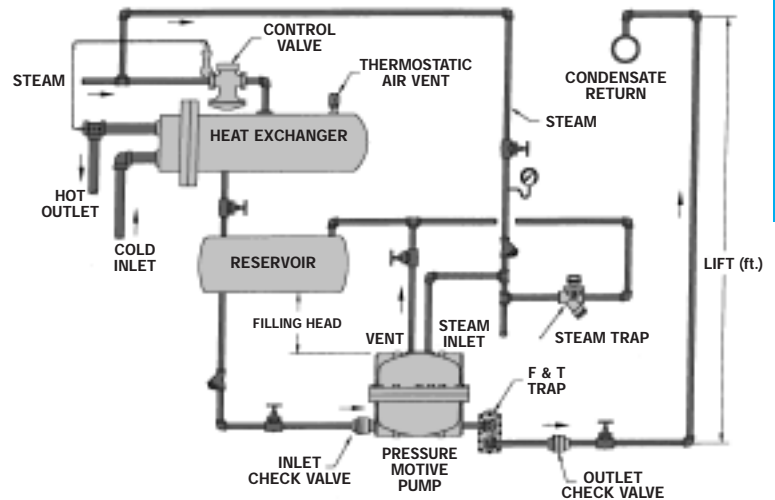

SOLUTION

USE A PRESSURE MOTIVE PUMP AS SHOWN.

When the temperature regulating valve is fully open, any condensate forming inside the heat exchangers will be pushed through the pump and steam trap into condensate return line. When the temperature regulating valve closes, any condensate forming inside the heat exchanger will drain by gravity into the pump tank. When the level inside the pump tank reaches the trip point, high pressure steam will drive the condensate from the tank into the condensate return line. **Note:** A larger steam trap than normally required to drain the heat exchanger must be used to handle the high instantaneous discharge rate of the pump.

CAPACITIES – Condensate (lbs/hr)

Motive Pressure (PSIG)	Back Pressure (PSIG)	6" Filling Head			
		Steam Motive		Air Motive	
		1"	1 1/4"	1"	1 1/4"
25	15	1200	1800	1720	2580
25	5	1970	2955	2265	3398
50	40	1200	1800	1640	2460
50	25	1480	2220	1980	2970
50	15	1860	2790	2220	3330
50	5	2240	3360	2485	3728
75	60	1160	1740	1935	2903
75	40	1640	2460	2185	3278
75	25	1960	2960	2340	3510
100	60	1415	2122	2020	3030
100	40	1825	2732	2280	3420
100	25	1985	2977	2420	3630
100	15	2175	3262	2455	3683
150	100	1120	1680	1456	2184
150	80	1220	1830	1525	2288
150	60	1570	2355	1885	2828

SIZING

The capacity of the PMPM is based on the inlet steam pressure, the system back pressure, and the amount of filling head available. The trap used in a pump trap combination must be sized to handle the instantaneous discharge of the pump.

Choose a F&T trap that will pass the condensate load at a 1/4 PSI differential pressure. The PMO of the steam trap must be higher than the motive inlet steam pressure. Consult factory for proper choice of steam trap.

HOW TO ORDER

- Specify:
- Model – PMPM
 - For pump/trap combination – to properly size the steam trap, specify condensate load (lbs/hr) and inlet motive pressure for the pump